

Safety Precautions

UV INKJET PRINTER
JFX200-2513 EX
JFX200-1213 EX
Safety Precautions

You can also download the latest manual from official website.

MIMAKI ENGINEERING CO., LTD.

<https://mimaki.com/>

D203453-30
Original instructions

TABLE OF CONTENTS

Introduction	3
For safe use	4
Symbols	4
Usage Warnings and Precautions	5
Cautions on Installation	11
Warning Labels	12
1. Usage Restrictions.....	16
Usage Restrictions.....	16
User Restrictions	16
Area Restrictions	16
2. Avoid These While Operating the Printer	17
Confirmation for agreement.....	21

Introduction

Thank you for purchasing the UV-LED curable inkjet printer JFX200-2513EX, JFX200-1213EX.

Read the safety precautions ("this document" hereinafter) thoroughly and make sure you understand its contents to ensure safe and correct use of the product.

Please note that the illustrations contained in this manual are intended to show functions, procedures, or operations and may sometimes differ slightly from the actual machine.

Unauthorized reproduction of any portion of this document is strictly prohibited.

© 2019 MIMAKI ENGINEERING Co., Ltd.

● DISCLAIMERS

- MIMAKI ENGINEERING REJECTS ALL LIABILITY FOR DAMAGE ARISING DIRECTLY OR INDIRECTLY FROM THE USE OF THE JFX200-2513EX, JFX200-1213EX ("THIS MACHINE" HEREINAFTER), WHETHER OR NOT THE PRODUCT IS FAULTY.
- MIMAKI ENGINEERING REJECTS ALL LIABILITY FOR DAMAGE, DIRECT OR INDIRECT, TO MATERIALS CREATED WHILE USING THIS MACHINE.
- USING THIS MACHINE IN CONJUNCTION WITH DEVICES OTHER THAN THOSE RECOMMENDED BY MIMAKI ENGINEERING MAY RESULT IN FIRE OR ACCIDENTS. SUCH INCIDENTS ARE NOT COVERED BY THE PRODUCT WARRANTY. MIMAKI ENGINEERING REJECTS ALL LIABILITY FOR DAMAGE, DIRECT OR INDIRECT, ARISING FROM SUCH INCIDENTS.
- USE ONLY GENUINE MIMAKI ENGINEERING INK AND MAINTENANCE LIQUID. USE OF OTHER PRODUCTS MAY RESULT IN FAILURES OR REDUCE PRINT QUALITY. SUCH INCIDENTS ARE NOT COVERED BY THE PRODUCT WARRANTY. MIMAKI ENGINEERING REJECTS ALL LIABILITY FOR DAMAGE, DIRECT OR INDIRECT, ARISING FROM SUCH INCIDENTS.
- DO NOT ATTEMPT TO REFILL THE INK BOTTLES WITH UNAUTHORIZED INK. SUCH INCIDENTS ARE NOT COVERED BY THE PRODUCT WARRANTY. MIMAKI ENGINEERING REJECTS ALL LIABILITY FOR DAMAGE, DIRECT OR INDIRECT, ARISING FROM SUCH INCIDENTS.
- USE ONLY GENUINE MIMAKI ENGINEERING ANTI FREEZING LIQUID. USE OF OTHER ANTI FREEZING LIQUID MAY CAUSE FAILURES OR REDUCE PRINT QUALITY. SUCH INCIDENTS ARE NOT COVERED BY THE PRODUCT WARRANTY. MIMAKI ENGINEERING REJECTS ALL LIABILITY FOR DAMAGE, DIRECT OR INDIRECT, ARISING FROM SUCH INCIDENTS.
- AVOID USING UV-LED UNITS OR UV POWER SUPPLY UNITS OTHER THAN THOSE SPECIFIED BY MIMAKI ENGINEERING. USING DEVICES OTHER THAN GENUINE MIMAKI ENGINEERING DEVICES MAY RESULT IN FAILURE, ELECTRIC SHOCK, OR FIRE. SUCH INCIDENTS ARE NOT COVERED BY THE PRODUCT WARRANTY. MIMAKI ENGINEERING REJECTS ALL LIABILITY FOR DAMAGE, DIRECT OR INDIRECT, ARISING FROM SUCH INCIDENTS.

● TV and radio interference



- The machine emits high-frequency electromagnetic radiation while operating. Under certain circumstances, this may result in TV or radio interference. We make no guarantee that this machine will not affect special radio or TV equipment.
-

If radio or TV interference occurs, check the radio or TV reception after turning off the machine. If the interference disappears when the power is turned off, the machine is likely to be the cause of the interference.

Try any of the following solutions or combinations of these solutions:











- Change the orientation of the TV or radio antenna to find a position where interference does not occur.
- Move the TV or radio away from this machine.
- Plug the TV or radio into a power outlet on a power circuit other than the power circuit to which this machine is connected.

For safe use

Symbols

In this document, symbols are used for explaining the contents of cautions on operation. The symbol to be displayed differs depending on the caution content. Please understand the meaning of each symbol and use this machine safely and correctly.

● Examples of symbols

Meaning		
	WARNING	Failure to observe the instructions given with this symbol can result in death or serious injuries to personnel. Be sure to read it carefully and use the printer properly.
	CAUTION	Failure to observe the instructions given with this symbol can result in minor or medium injuries to personnel.
	GENERAL WARNING	This symbol indicates that the items shown need to be noted. Specific notes are drawn in the figure  .
	GENERAL MANDATORY ACTION	This symbol indicates that the action shown must be executed. Specific instruction is drawn in the figure  .
	GENERAL PROHIBITION	This symbol indicates that the action shown is prohibited. Specific action that is prohibited is drawn in the figure  .
	IMPORTANT	Important notes for the use of this printer are given with this symbol. Understand the notes thoroughly to operate the printer properly.
	HINT	Useful information is given with this symbol. Understand the notes thoroughly to operate the printer properly.
	REFERENCE	This symbol indicates the reference page for related contents. Click the text to display the corresponding page.

Usage Warnings and Precautions

● In the event of abnormal conditions

WARNING



- If someone swallows ink or cleaning solution by mistake, keep him or her quiet and take them to see a doctor immediately. Do not let allow the person to swallow the vomit.
- If you inhale a great deal of vapor and feel ill, immediately move to a location with plenty of fresh air, and keep yourself warm and quiet. Consult a doctor as soon as possible.
- In the unlikely event that a foreign object such as metal, water, liquid enters the inside of this machine, turn off the power immediately. Afterwards be sure to unplug the power plug from the outlet. If used as it is, it may cause fire or electric shock.
- If ink leaks, turn off the main power switch and unplug the power cable. After that, contact your local distributor, our sales office, or service center.



- Immediately turn off the main power supply and disconnect the power cable from the machine if a problem such as an abnormal smell, smoke, or sign of spark occurrence is detected in the machine. If used as it is, it may cause fire or electric shock. Check first that the machine no longer produces smoke, and contact your distributor or a sales office of MIMAKI for repair.
- Never repair your printer by yourself since it is very dangerous to do so.

● Handling of ink and cleaning solution

WARNING



- Make sure to read the Safety Data Sheet (SDS) before handling ink and washing liquid.
- Some constituents are toxic to aquatic life. Prevent leakage into natural water systems or domestic wastewater.
- If ink adheres to the skin or clothing, immediately rinse with soap and water. If you get the ink in your eyes, wash them immediately with water and consult a doctor.
- Discard the waste ink according to the local regulations of the area where this printer is used.
- Be sure to store the ink and cleaning solution in a cold dark location. Store the cleaning solution in a location that is out of the reach of children.



- When handling ink and washing liquid, pay close attention to ventilation and be sure to wear the included safety glasses and gloves. The ink or washing liquid may get in your eyes.



CAUTION



- Use of ink other than that specified will damage this printer. Malfunctions caused due to the use of alternative ink are out of the scope of warranty. Please understand that the cost of repairs in this case is to be borne by the customer.
- Never refill an ink bottle with ink. Malfunctions caused due to refilling of the ink bottle are out of the scope of warranty, and our company does not assume any responsibility for the same.
- Do not use the ink designed for this printer with other printers. Doing so may cause damage to the printer.

● Handling of ink bottles

WARNING



- Precautions regarding ink are indicated on the Ink bottle. Read these carefully and make sure you understand the contents before using the product.
- Store ink bottles and the waste ink tank in a location that is out of the reach of children.

CAUTION



- If the ink bottle is moved from a cold to a warm place, leave it for more than 3 hours before use.
- Open the ink bottle just before use and be sure to use it promptly. If the bottles are left open for a long time, the printing quality may degrade.
- For device protection, do not use any ink other than the dedicated ink.



- Do not strike the ink bottle with great force nor shake it violently. Doing so may cause ink to leak out of the bottle.

● Be Careful with Moving Parts

WARNING



- Do not place your fingers or other parts of body close to dangerous moving parts. There is a danger of injury.

● Warning Labels

CAUTION



- Warning labels are affixed to this printer. Be sure to fully understand the warnings indicated on the labels. If any of the warning labels has become so soiled that the warning message is illegible or has come off, purchase a new one from your local distributor.

● Ultraviolet Rays (UV), UV-LED

WARNING



- The LED UV unit becomes hot inside. Turn off the LED UV unit and perform maintenance once the device cools down adequately. It may cause burns.



- A small amount of UV light leaks out around the LED UV unit. Wear gloves, long-sleeved clothes, light-shielding mask, light-shielding glasses, and similar protection so that your skin and eyes will not be exposed to UV light.

(1) Direct exposure of skin or eyes to UV light may result in inflammation or skin cancer.

(2) Even if UV light is weak and not likely to cause inflammation, repeated exposure to it may result in a chronic disease.

(3) Viewing a lit UV lamp with the naked eye may cause eye pain or visual impairment.

(4) There is a danger of eye damage due to UV light.

- Acute impairment: sensation of having a foreign body in the eye, pain, flowing tears
- Chronic impairment: cataract, etc.



- Never look at the LED UV with your naked eyes when lit up. Doing so may cause pain in your eyes or visual impairment. Be sure to wear the included safety glasses.



- Do not apply ultraviolet (UV) light directly to your skin. Doing so may irritate your skin.

CAUTION



- Touching hot parts such as the LED UV with combustible materials may cause fire or smoke to be emitted. Leaving combustible materials under the LED UV unit for a couple of minutes may also cause fire or smoke emittance.



- Be sure to wear the included gloves when handling the glass on the bottom of the LED UV unit, and never touch it with bare hands. Doing so may significantly lower the UV ink curing level. If the glass becomes dirty, wipe it with clean gauze moistened with ethanol. (Do not use ethanol for cleaning the exterior cover. Doing so will cause the paint to peel off.)



- Always use only a LED UV device and UV power supply unit recommended by Mimaki. The use of any product other than our recommended products may lead to fire or machine damage. Malfunctions caused due to the use of non-recommended products is out of the scope of warranty, and our company does not assume any responsibility for the same.
- Do not drop the glass components, bump them against things, use excessive force on them or scratch them.

● Grounding Work

WARNING



- Increasing the number of power outlets requires installation work to provide grounding to protect against electric shock.
- Carry out the grounding work.
- Always perform grounding to prevent electrocution accidents.

● Installation Location and Operating Environment

WARNING



- To prevent ignition of the ink, do not allow any open flames in the place where the unit is used.



- Be sure to set up an appropriate ventilation system if using this printer in a closed room or a room with poor ventilation.
- This machine is not an explosion-proof type. Do not use the machine in a flammable atmosphere. There is a danger of explosion.
- When constructing an exhaust outlet, please observe the following cautions to prevent malfunctioning of this printer.
 - (1) The extractor outlet must be installed in accordance with applicable local EHS (environmental, health, and safety) guidelines.
 - (2) If the extractor outlet is fitted with a shutoff valve, the valve must be open when this product is in use.



- Do not use the machine in a flammable atmosphere (such as gasoline, flammable sprays, thinners, lacquers, dust, etc.). It may cause a fire or electric shock by ignition.
- Do not bring paper or cloth close to the LED UV unit or cover LED UV unit with it. Doing so may cause fire.



- Do not use in humid places. Do not splash water onto this machine. It may cause fire, electric shock or malfunctioning.



- Keep children away from this machine.

CAUTION



- Use the printer in a room with as little dust as possible.
- Keep children away from this machine.
- If dust adheres around the head, it may cause ink droplets to fall. Execute head cleaning.
- Maintain this printer in a level horizontal position.

● Do Not Climb on the Table

WARNING



- Never climb on the table where the machine is placed. Doing so may cause the board surface accuracy to go wrong.

● Power supply and voltage

WARNING



- This machine has parts that generate high voltage. Get the electrical work done only from a licensed electrician.



- The set of power cables provided with this machine is for use with this machine only. Cannot be used with other electrical devices. Also, please do not use the power cable set other than the enclosed. Doing so may result in fire or electric shocks.
- Do not use extension cords. Doing so may result in fire or electric shocks.
- Keep the power plug prong clear of any foreign object such as a piece of metal. Failure to do so may result in a fire or electric shocks.
- Do not plug too many leads into a single socket. Doing so may result in fire or electric shocks.
- Do not use the machine if the power cable or plug is damaged. Using the machine with damaged power cable may result in fire or electric shocks. Contact your service representative for replacement of the cable.
- Do not handle the power plug with wet hands. Doing so may result in electric shocks.
- Grasp by holding the plug itself when removing the power plug from wall outlet. Holding and pulling the power cable may damage the cable, leading to fire or electric shocks.
- Do not use the device at a power supply frequency other than the one indicated. Doing so may result in fire or electric shocks.
- Do not use the device at a power supply frequency other than the one indicated. Doing so may result in fire or electric shocks.



- Use this printer with the indicated power specifications. Be sure to connect the power cable plug to a grounded socket in order to prevent fire and electric shock. Failure to do so may result in fire or electric shocks.



- Take care not to damage, break or work upon the power cable. If a heavy material is placed on the power cable, or if it is heated or pulled, the power cable can break, thus resulting in fire or electric shocks.
- The main power circuit breaker should be turned on only by personnel with sufficient knowledge about operating this printer.

● Power Supply

WARNING



- Make sure the breaker is always on.

● Power Cable

WARNING



- Use the power cable provided.

● Disposal

WARNING



- If you want to dispose of this machine, please contact your local distributor or service center. If you want to dispose the machine by yourself, please contact an industrial waste processor.
- Give the waste ink or the ink bottles that you no longer to your local distributor or service center. If you want to dispose of them by yourself, please contact an industrial waste processor or dispose them according to local regulations.

● Handling Vacuum

WARNING



- Never disassemble or modify the vacuum. Also, do not touch the relief valve (pressure regulating valve) or block the vacuum exhaust port. This can cause a decrease in suction force, heat generation or malfunctions. (The vacuum is directly below the table.)

CAUTION



- Using this machine in a low temperature environment can sometimes cause the vacuum to emit a highpitched sound, but this is not a malfunction.

● Handling the antifreeze liquid

WARNING



- Use the antifreeze liquid recommended by Mimaki. There is a risk of cooling device failure if other antifreez liquids is used. Malfunctions caused due to the use of other anti freezing liquids is out of the scope of warranty, and our company does not assume any responsibility for the same.
- Do not directly touch the antifreeze liquid.
In case of touching skin or clothing, use soap and immediately flush it with running water.
If you get antifreeze liquid in your eyes, immediately and thoroughly wash your eyes with clean water. Then, consult a doctor as soon as possible.
- Be sure to read the Safety Data Sheet (SDS) before using the antifreeze liquid.
- If someone accidentally swallows antifreeze liquid, try to get the person to vomit, and then consult a doctor as soon as possible.
- Avoid causing ignition due to static electricity, impact sparks, and similar causes.
- If you accidentally touch hot anti freeze mixture, immediately rinse it off with soap and water, cool adequately with ice water and then consult a doctor as soon as possible.
- Use the following methods to dispose of unneeded anti freezing liquid.
 - (1) Absorb them into such materials as sawdust or a waste cloth, and then incinerate in an incinerator
 - (2) Clearly indicate the contents of the waste to be disposed of and subcontract the treatment of the waste to a licensed industrial waste disposal company



- When handling the anti freezing liquid, be sure to wear the included safety glasses and gloves.



CAUTION



- Be sure to store the antifreeze liquid in a cold and dark place. Also keep it out of the reach of children.

● Do not disassemble or modify this printer

WARNING



- Never disassemble or modify this machine or ink bottle. Disassembling or modifying will result either in electric shock or malfunction of this machine.

● Handling Media

WARNING



- Do not leave the media set on the machine when returning home for the night. This can cause dust to adhere to the media.

CAUTION



- Use our recommended media to ensure stable and high-quality printing.
- Be careful about the expansion and contraction of the media. Do not use media immediately after removing from the packaging. Media may expand or shrink depending on the temperature and humidity of the room. After opening the package, let the media sit for at least 30 minutes at the place of use before installing it in the device.
- Do not use curled media. This not only causes media jams, but also affects image quality. Straighten the media before using if it is severely curled. When storing coated fix-sized paper in rolls, make sure the coated surface is on the outside.
- Keep the media away from dust. Wiping dust off the media creates static electricity, which has a counterproductive effect.

● Maintenance

WARNING



- To prevent electric shocks during maintenance, always turn the main power switch off, and remove the power plug. Capacitors of some units may take one minute to discharge. Accordingly, start maintenance work three minutes after turning off the main power circuit breaker and disconnecting the power plug.



- Never touch the areas around where high temperature caution plaques are affixed. Otherwise, you may burn yourself. If you need to touch the high temperature area, wear heat-insulating gloves to protect your hands.



- When cleaning the head, wiper or cap, be sure to wear the included safety glasses and gloves.





- Using the printer in a place exposed to water will increase the possibility of electric leakage. Avoid using the printer in places exposed to water. Electrical leakage may lead to electric shock of personnel or fire.

CAUTION



- Foreign materials and dust may accumulate on the conductive and insulating parts after using this printer for an extended period, resulting in electrical leakage. Periodically clean such parts.
- Do not blow compressed air. Foreign materials and dust may be scattered, get inside the conductive parts and cause malfunction. Be sure to use a vacuum cleaner to vacuum off foreign materials and dust.
- To prevent accidents, be sure to carry out periodic inspection and replace parts requiring periodic replacement.
- There are parts to be replaced periodically on this machine. We recommend concluding a maintenance contract.
- After this printer is used long time, foreign materials or dust gathered on the stabilizer or other parts may cause electrical leakage or insulation deterioration, resulting in fire or smoke emittance. Periodically clean this printer and replace the deteriorated parts detected by insulation resistance measurement.
- Screws of conductive or other parts may become loose after extended use of this printer, resulting in fire or smoke emittance. Periodically tighten the screws.

Cautions on Installation

When installing this machine, take the following precautions.

WARNING



- This machine should be installed in a dedicated private room, in a location where it can be reliably isolated by physical means such as an enclosure. The isolated area should be set up so that no one can easily reach the printer and ink supply unit.
- This isolated area should be prohibited for everyone except the trainees of our safety education program or those who have been trained by such a trainee.
If an untrained person enters the restricted area while the machine is in operation, there is a risk of accidental contact with the Y-bar that is in the process of printing, resulting in injury.
- This machine should only be operated by the trainees of our safety education program or those who have been trained by such a trainee.

CAUTION



Use the printer under the following environmental conditions:

- Operating environment: 15 to 30°C (59 to 86°F) 35 to 65% Rh (without condensation)
- Accuracy assurance temperature: 20 to 25°C (68 to 77°F)



Do not use the printer in the following environments:

- Exposed to direct sunlight
- Places that are not level
(If the machine is not level, it may cause poor image quality)
- Where vibration occurs
- Exposed to direct air flow from an air conditioner or similar location
- Near where fire is used
- Places with lots of dust
- Places where there are chemicals

Warning Labels

As shown below, various warning labels are attached to the machine. Make sure you fully understand the details indicated on the various warning labels.





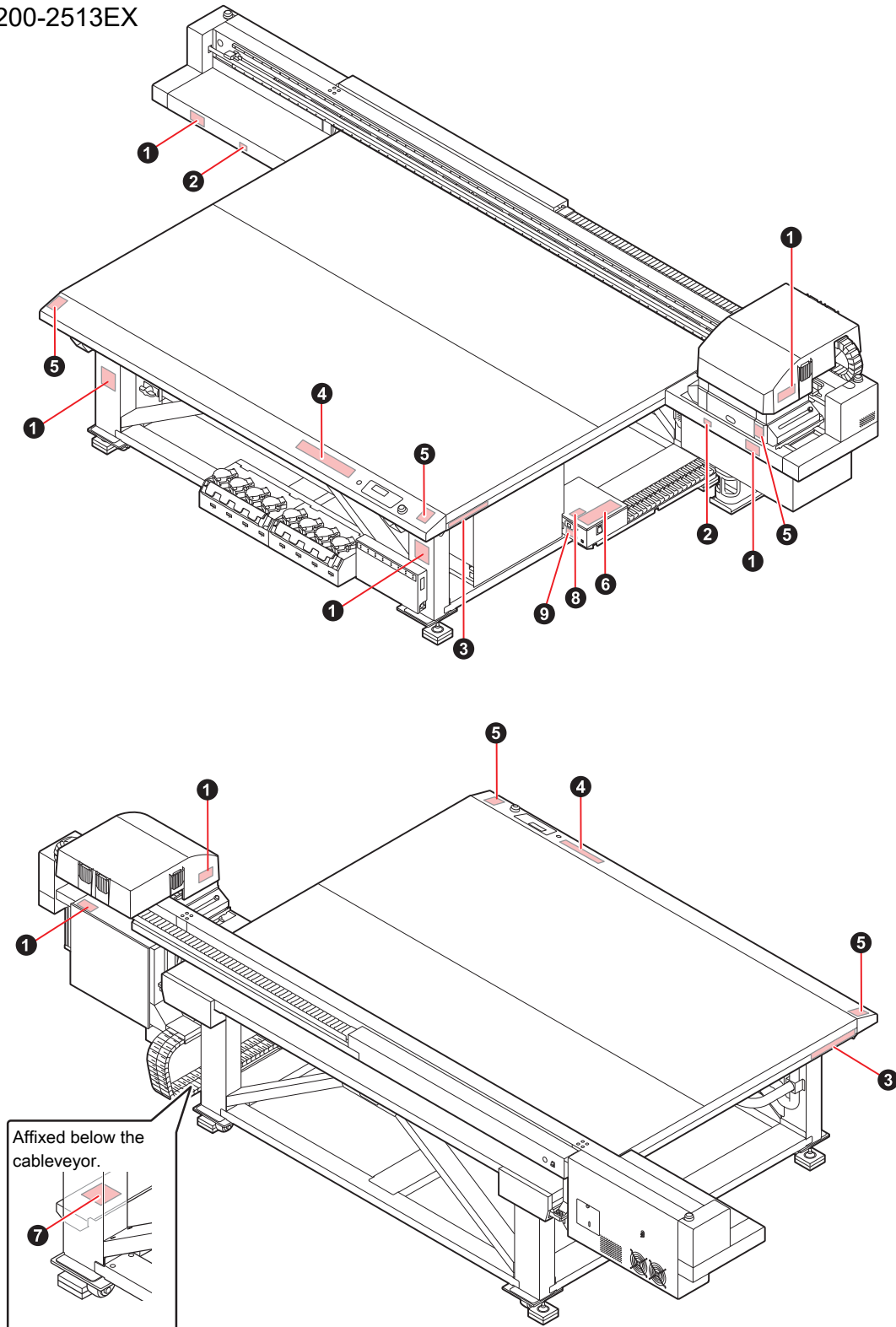

If any of the warning labels become dirty and illegible or peel off, contact your local dealer or our service office and request new warning labels.

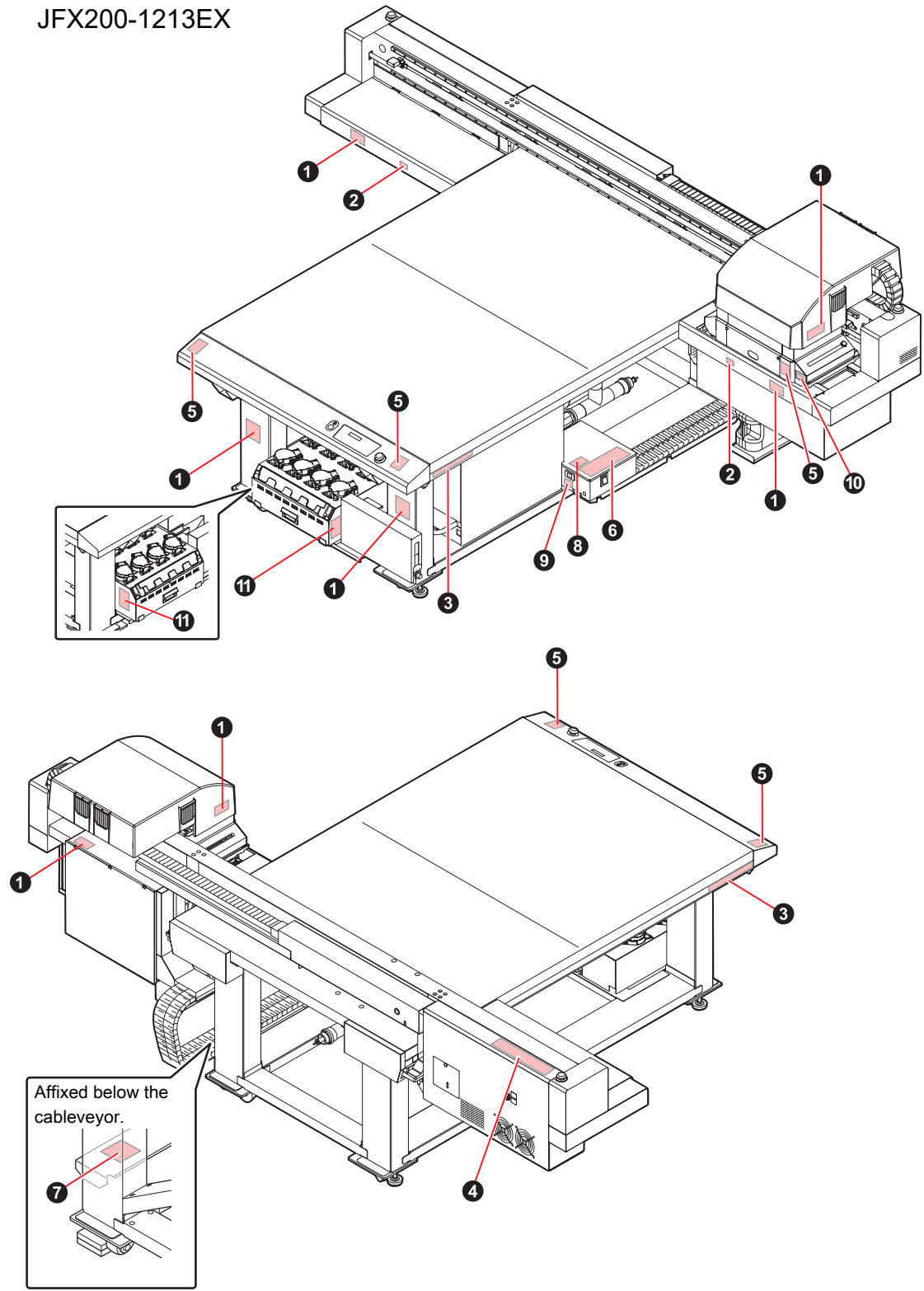



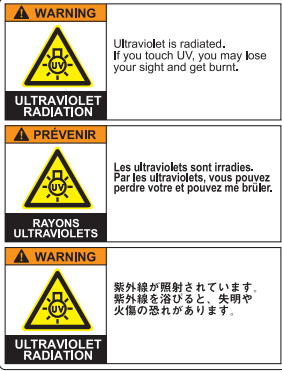
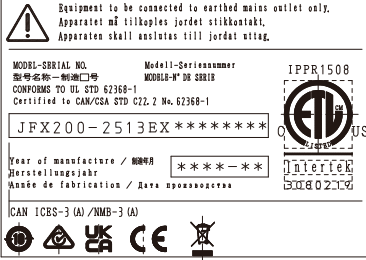
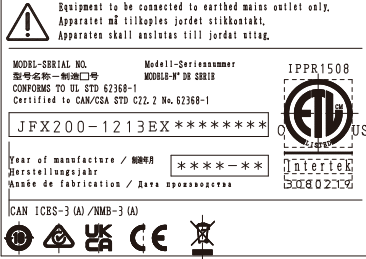

JFX200-2513EX



JFX200-1213EX



No.	Order code	Label
1	M909381	
2	M903330	
3	M906115	
4	M902663	
5	M905980	
6	M916117 (JFX200-2513EX)	
	M919315 (JFX200-1213EX)	
7	M909385	

No.	Order code	Label				
8	M903281	<p>See SET UP GUIDE before connecting to the supply. 電源を接続する前に、必ずセットアップガイドを読むこと。 在接通电源之前请一定阅读安装说明书。</p>				
9	M907935					
10	M919473 (JFX200-1213EX only)	<table border="1" style="width: 100%; text-align: center;"> <tr> <td>RISK GROUP 2</td> </tr> <tr> <td> <ul style="list-style-type: none"> •CAUTION UV emitted from this product. •Eye or skin irritation may result from exposure. Use appropriate shielding. </td> </tr> <tr> <td>GRUPE DE RISQUE 2</td> </tr> <tr> <td> <ul style="list-style-type: none"> •ATTENTION : UV emis par ce produit. •L'exposition peut provoquer une irritation yeux ou de la peau. Use appropriate shielding. </td> </tr> </table>	RISK GROUP 2	<ul style="list-style-type: none"> •CAUTION UV emitted from this product. •Eye or skin irritation may result from exposure. Use appropriate shielding. 	GRUPE DE RISQUE 2	<ul style="list-style-type: none"> •ATTENTION : UV emis par ce produit. •L'exposition peut provoquer une irritation yeux ou de la peau. Use appropriate shielding.
RISK GROUP 2						
<ul style="list-style-type: none"> •CAUTION UV emitted from this product. •Eye or skin irritation may result from exposure. Use appropriate shielding. 						
GRUPE DE RISQUE 2						
<ul style="list-style-type: none"> •ATTENTION : UV emis par ce produit. •L'exposition peut provoquer une irritation yeux ou de la peau. Use appropriate shielding. 						
11	M907764 (JFX200-1213EX only)	<table border="1" style="width: 100%; text-align: center;"> <tr> <td>  注意 CAUTION ATTENTION </td> </tr> <tr> <td>  </td> </tr> <tr> <td> 上部に乗るな DO NOT STEP ON TOP NE GRIMPEZ PAS DESSUS </td> </tr> </table>	 注意 CAUTION ATTENTION		上部に乗るな DO NOT STEP ON TOP NE GRIMPEZ PAS DESSUS	
 注意 CAUTION ATTENTION						
						
上部に乗るな DO NOT STEP ON TOP NE GRIMPEZ PAS DESSUS						

1. Usage Restrictions

Usage Restrictions

This machine can be dangerous due to parts that move at high speeds, parts with high temperature and UV curing units. This machine is to be used only by those having complete understanding of dangers associated with these parts.

User Restrictions

This machine should only be operated by the trainees of our safety education program or those who have been trained by such a trainee.

Area Restrictions

- Only adequately trained and versed individuals are allowed to come closer to the equipment. Area restrictions should be set up for the area indicated in the figure below. The area restrictions must include appropriate measures to clearly indicate that this is a hazardous area, such as by installing the machine in a dedicated room or by setting up an enclosure.
- Access to the hazardous area must be prohibited for all persons except those who have received safety training from Mimaki Engineering or persons who have received training from them. If an untrained person enters the restricted area while the machine is in operation, there is a risk of accidental contact with the Y-bar that is in the process of printing, resulting in injury.
- Follow EN ISO13857 standards when securing the area with safety trellis.
- If the machine is installed in a dedicated room, a lock or safety interlock should be fitted to the room door, and a risk assessment should be conducted for the installation site before use.

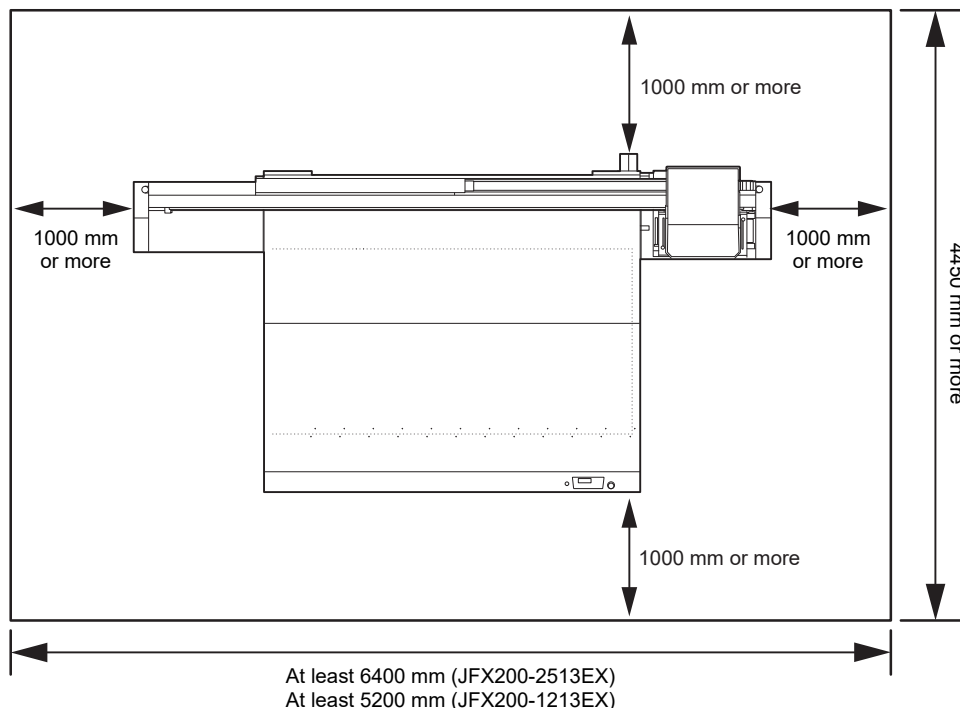

2. Avoid These While Operating the Printer

Doing the things mentioned below when the printer is in operation might result in an injury.

- **Keep your face, hands, and all other body parts at a safe distance from the carriage area.**



- Do not bring your face, hands, or any other part of your body close to or into the gap between the carriage and the Y-bar.



- Do not bring your face, hands, or any other part of your body close to or into the gap between the carriage and table or station.



- **Keep your face, hands, and all other body parts at a safe distance from the gap between the Y-bar and table.**



- Do not bring your face, hands, or any other body parts close to or into the gap between the Y-bar and table.



- **Keep your face, hands, and all other body parts at a safe distance from moving parts.**



- Do not bring your face, hands, or any other body parts close to or into the Y-bar belt.



- **Keep your face, hands, and all other body parts at a safe distance from the cable carrier section, and do not place any objects on top.**



- Do not bring your face, hands, or any other body parts close to or into the cable carrier section below the Y-bar and table, and do not place any object on top.

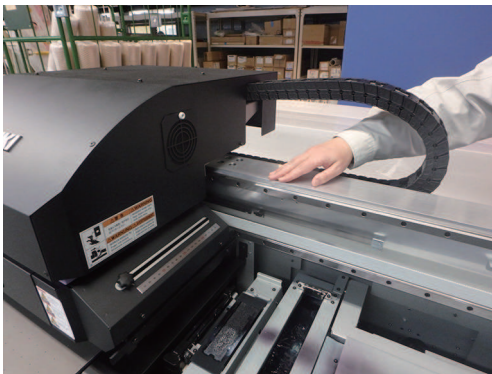

- **Keep your face, hands, and all other body parts at a safe distance from the area under the table.**



- Do not crawl under the table or bring your face, hands, or any other body parts into the space under the table.

- **Keep your hands and other objects off the table.**



- Do not place your face, hands, other body parts, or any objects other than the media (less than 50 mm thick) on the table.



● **Do not look directly at the UV-LED.**



- Avoid looking directly at the UV-LED. Take special care when working while seated as the carriage will be roughly at eye level. Also, you may burn yourself from the LED UV unit and the parts around it, that have turned hot. Be careful not to touch.

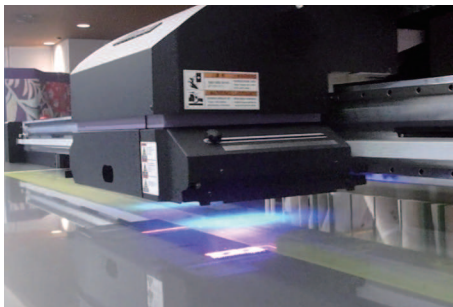

● **Do not disturb the carriage operation.**



- Do not forcibly move the carriage while it is in motion (during printing, cleaning, or other operations).

● **Do not place any object in front of the exhaust port of suction vacuum**



- The object may get deformed due to the heat released from the exhaust port.

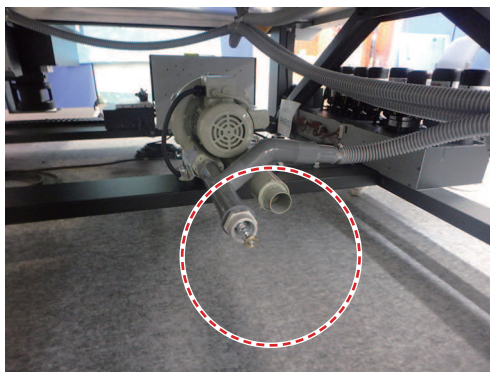

● **Be careful not to accidentally press the switch on the control panel.**



- Pressing this switch accidentally may cause sudden operation leading to an unexpected accident.

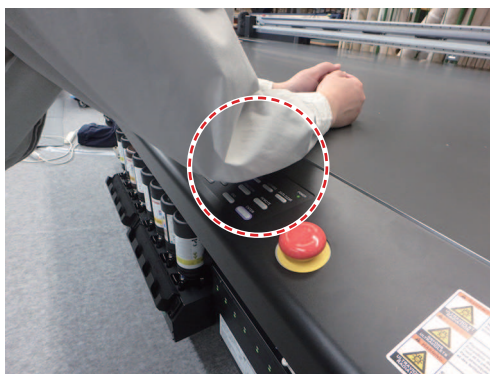

● **Wear safety glasses when using the machine**

It is recommended to wear safety glasses when using the machine to prevent eye damage due to UV light leakage.

● Pay attention to following when replacing the ink

- To prevent the ink from sticking to your hands or eyes when it splashes, be sure to wear the included safety glasses and gloves.
- Do not pull the ink cover too much.
Pulling it too much might damage the tubes and cables.
- Replace the ink bottle after cleaning the surroundings with a waste cloth, etc. The portion around the bottle becomes dirty as the ink oozes from the float part.

● Wear safety glasses and gloves when performing maintenance

When performing maintenance such as ink replacement, be sure to wear the included safety glasses and gloves.

Also, wear a gas mask if necessary.

Confirmation for agreement

Copy for customer

Confirmation for agreement

I agree to make my employees take proper safety training course performed by your company at installing this machine in accordance with the document "Safety Precautions" (D203453) of this machine (JFX200-2513EX /JFX200-1213EX). I also agree that only the employees who took the relevant safety training course or those who took training from him/her can use this machine.

Date: _____

Company name: _____

Representative: _____

Cutoff line	Sign	Date	Cutoff line

Copy for maker

Confirmation for agreement

I agree to make my employees take proper safety training course performed by your company at installing this machine in accordance with the document "Safety Precautions" (D203453) of this machine (JFX200-2513EX /JFX200-1213EX). I also agree that only the employees who took the relevant safety training course or those who took training from him/her can use this machine.

Date: _____

Company name: _____

Representative: _____

JFX200-2513EX /JFX200-1213EX Safety Precautions

January, 2024

MIMAKI ENGINEERING CO.,LTD.

2182-3 Shigeno-otsu, Tomi-shi, Nagano 389-0512 JAPAN

D203453-30-17102024

